

NRSA Series
SMD Power Inductors For Automotive
Size 5020

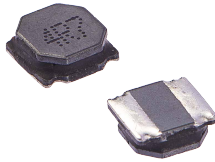

FEATURES

- Magnetic shield type wound inductor for power circuits using a ferrite magnetic material
- High magnetic shield construction and compatible with high-density mounting.
- Larger current and lower Rdc were achieved by optimizing the ferrite core figure.
- Operating temperature: -55 to +125°C(including self-temperature rise)
- AEC-Q200 qualified
- Quantity: 2500pcs

APPLICATION

- Car navigation, car stereo and car accessories only

Dimensions: [mm]

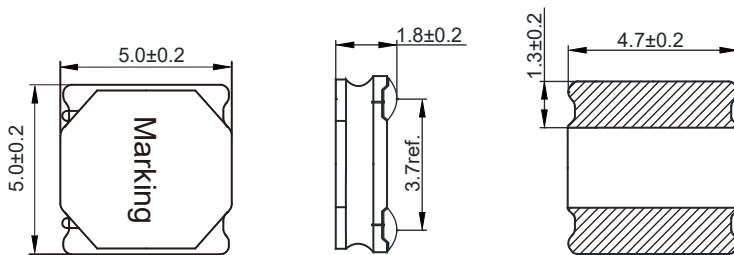

Land Pattern: [mm]

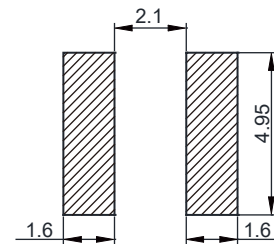

Electrical Properties:

Part No	L@100KHz/1V (μH)	Tolerance	I _{SAT} Typ. (A)	I _R Typ. (A)	R _{DC} ±20% (mΩ)
NRSA5020-1R0N	1.0	±30%	5.00	4.10	20
NRSA5020-1R2N	1.2	±30%	4.80	3.80	20
NRSA5020-1R5N	1.5	±30%	4.50	3.50	25
NRSA5020-2R2M	2.2	±20%	4.10	3.30	32
NRSA5020-2R7M	2.7	±20%	3.80	3.00	38
NRSA5020-3R3M	3.3	±20%	3.50	2.80	43
NRSA5020-4R7M	4.7	±20%	2.70	2.40	60
NRSA5020-5R6M	5.6	±20%	2.40	2.10	69
NRSA5020-6R8M	6.8	±20%	2.10	1.90	90
NRSA5020-8R2M	8.2	±20%	1.90	1.75	98
NRSA5020-100M	10	±20%	1.70	1.60	110
NRSA5020-120M	12	±20%	1.40	1.40	135
NRSA5020-150M	15	±20%	1.30	1.25	165
NRSA5020-180M	18	±20%	1.20	1.17	190
NRSA5020-220M	22	±20%	1.10	1.10	225
NRSA5020-330M	33	±20%	0.80	0.80	335
NRSA5020-470M	47	±20%	0.70	0.70	460

I_R will cause the coil temperature rise approximately Δt40 °C

I_{SAT} will cause L to drop approximately 30% .

Typical Electrical Characteristics:

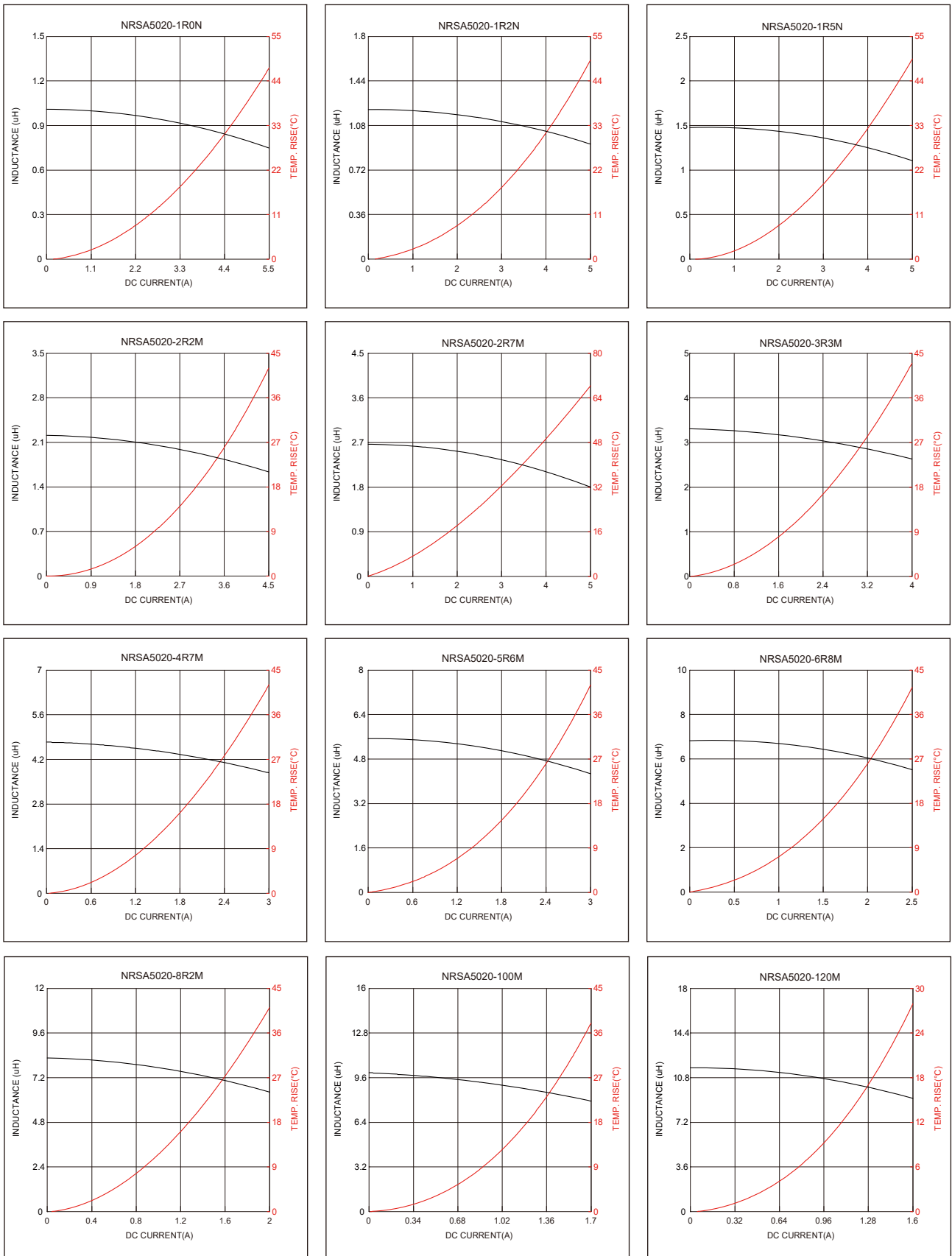

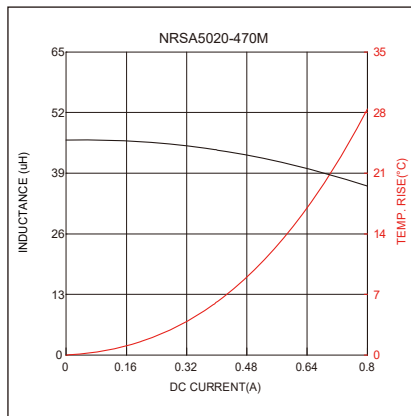
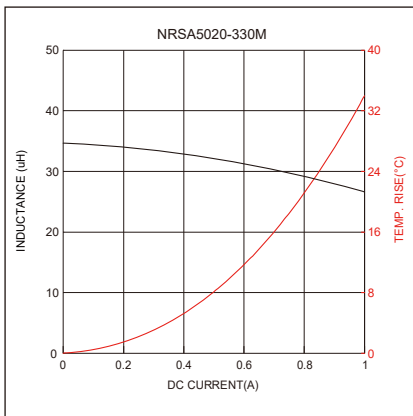
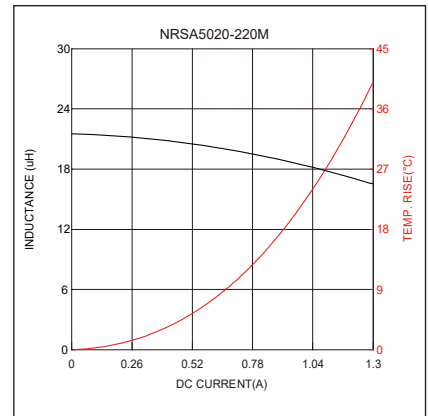
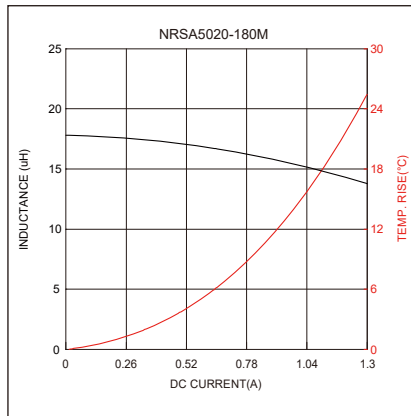
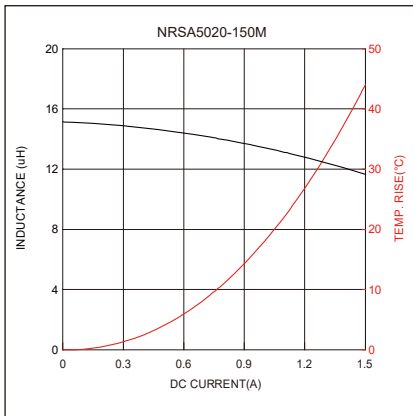

Soldering Reflow:

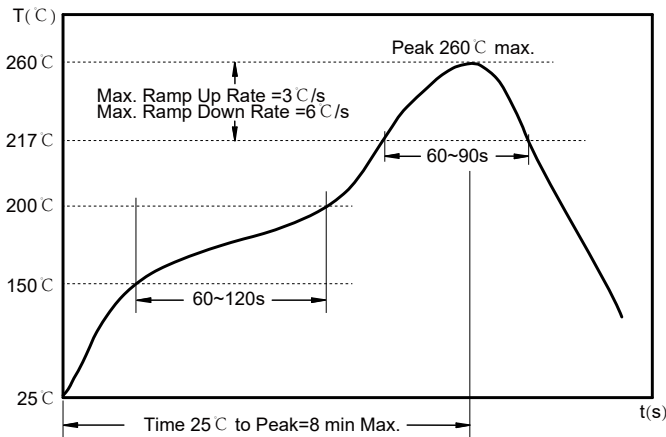

Preheat condition: 150 ~200 °C / 60~120 sec.
 Allowed time above 217 °C : 60~90 sec.
 Max temperature: 260 °C .
 Allowed Reflow time: 2x max.

Packaging Information:

Tape Dimension:

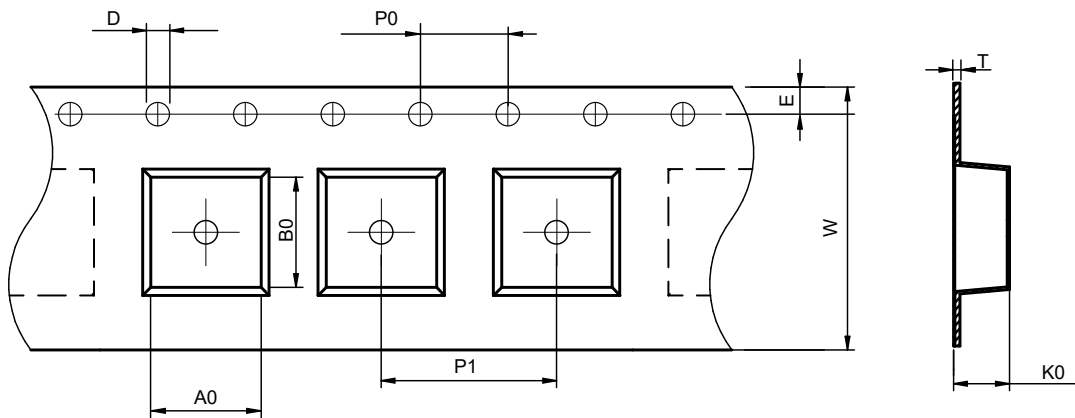

Series	A0 (mm)	B0 (mm)	D (mm)	P0 (mm)	P1 (mm)	W (mm)	K0 (mm)	E (mm)	T (mm)
NRSA5020	5.3±0.1	5.3±0.1	1.5±0.1	4.0±0.1	8.0±0.1	12.0±0.3	2.3±0.1	1.75±0.1	0.35±0.05

Peel force of top cover tape:

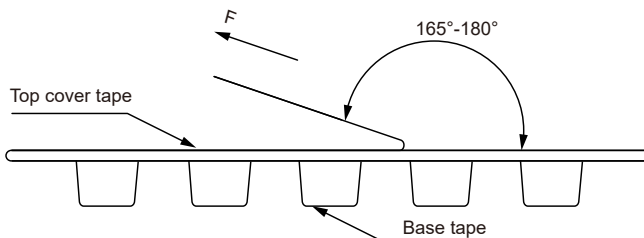

The peel force of top cover tape shall be between 0.3 to 1.17 N

Product Marking:

Marking	Printing (Inductance)
---------	-----------------------

Reel Dimension: [mm]

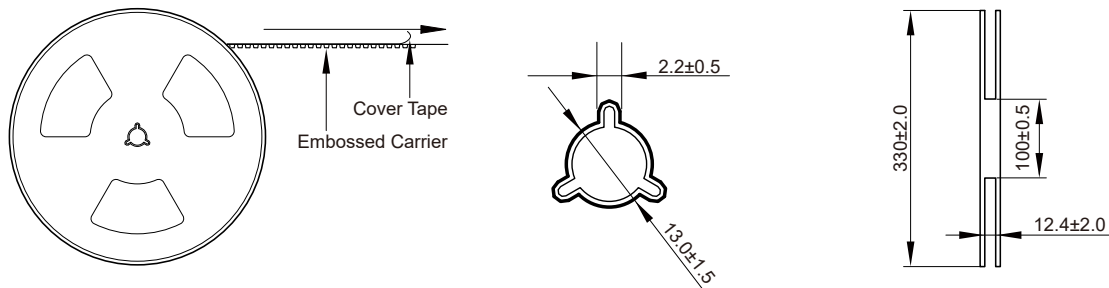

Packaging Quantity:

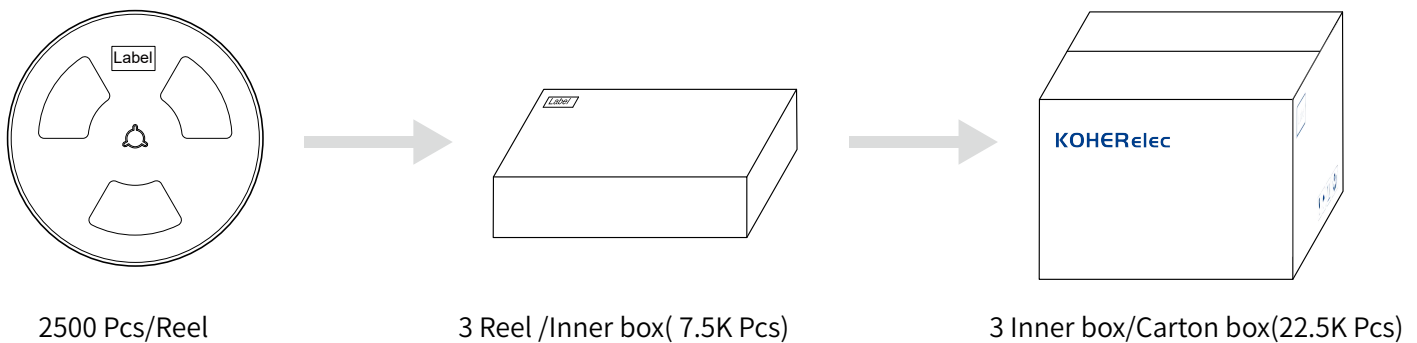

Cautions and Warnings:

Storage Conditions:

- The storage period is within 12 months after the completion of production. Be sure to follow the storage conditions (temperature: -5 to 35°C, humidity: 75% RH Max).If the storage period elapses, the soldering of the terminal electrodes may deteriorate.The warranty period is one year.
- Product should not be exposed to environment with high temperature, high humidity, dust, corrosive gas and etc.
- Products should be handled with care to avoid damage or contamination from perspiration and skin oils.
- Please always handle products carefully to prevent any damage caused by dropping down or inappropriate removing.

Operation Instructions:

- Self heating (temperature increase) occurs when the power is turned ON, so the tolerance should be sufficient for the set thermal design.
- Before soldering, be sure to preheat components.The preheating temperature should be set so that the temperature difference between the solder temperature and chip temperature does not exceed 150°C.
- Soldering corrections after mounting should be within the range of the conditions determined in the specifications.If overheated, a short circuit, performance deterioration, or lifespan shortening may occur.
- Generally, Koher might not be familiar with either customer's specific application or actual requests as customer does.As a result customer shall be responsible for checking and confirming whether Koher product with the performance described in the product specification is suitable for using in customer's particular application or not.